

(No Model.)

3 Sheets—Sheet 1.

H. N. KENNEDY.
CENTERING MACHINE.

No. 533,472.

Patented Feb. 5, 1895.

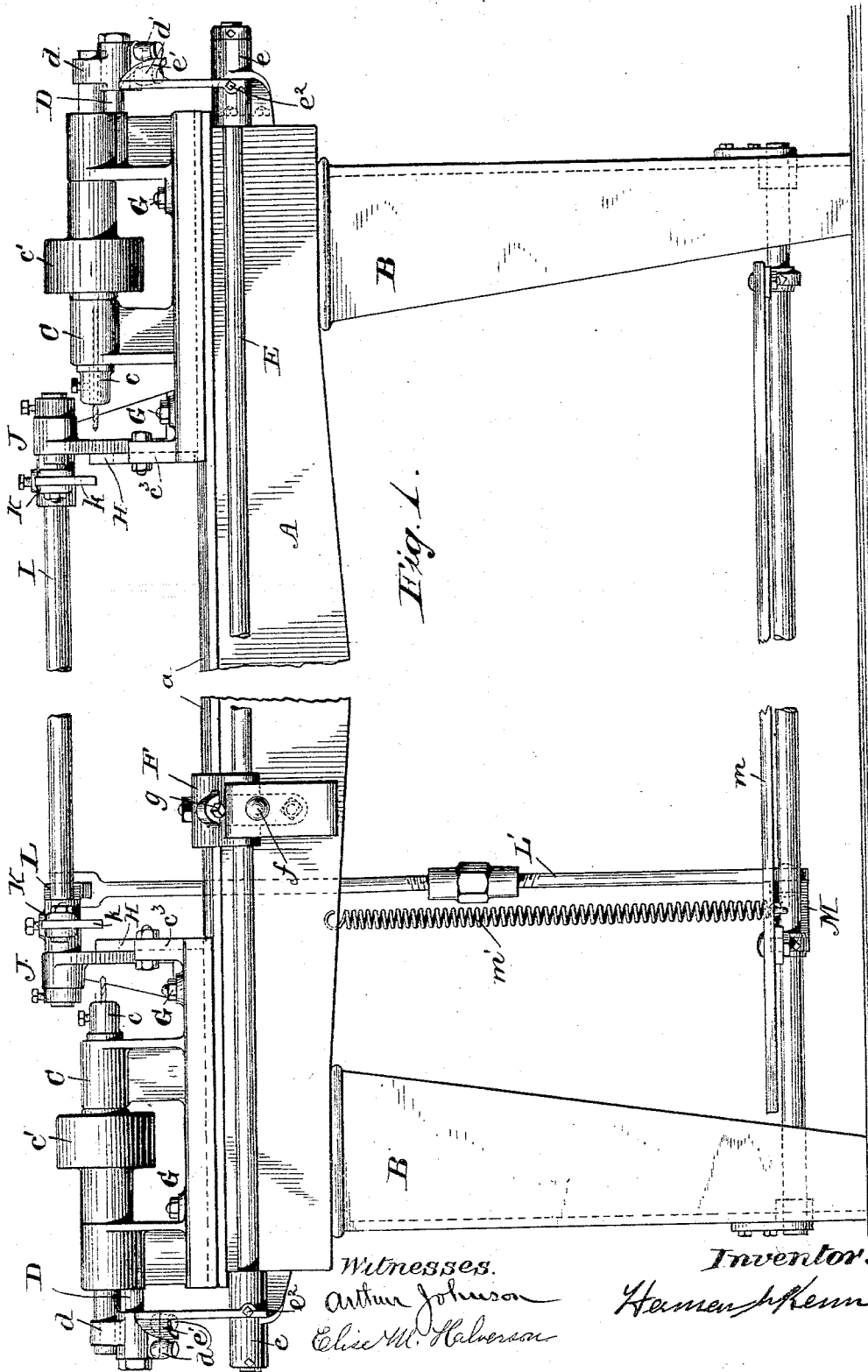

(No Model.)

3 Sheets—Sheet 2.

H. N. KENNEDY.
CENTERING MACHINE.

No. 533,472.

Patented Feb. 5, 1895.

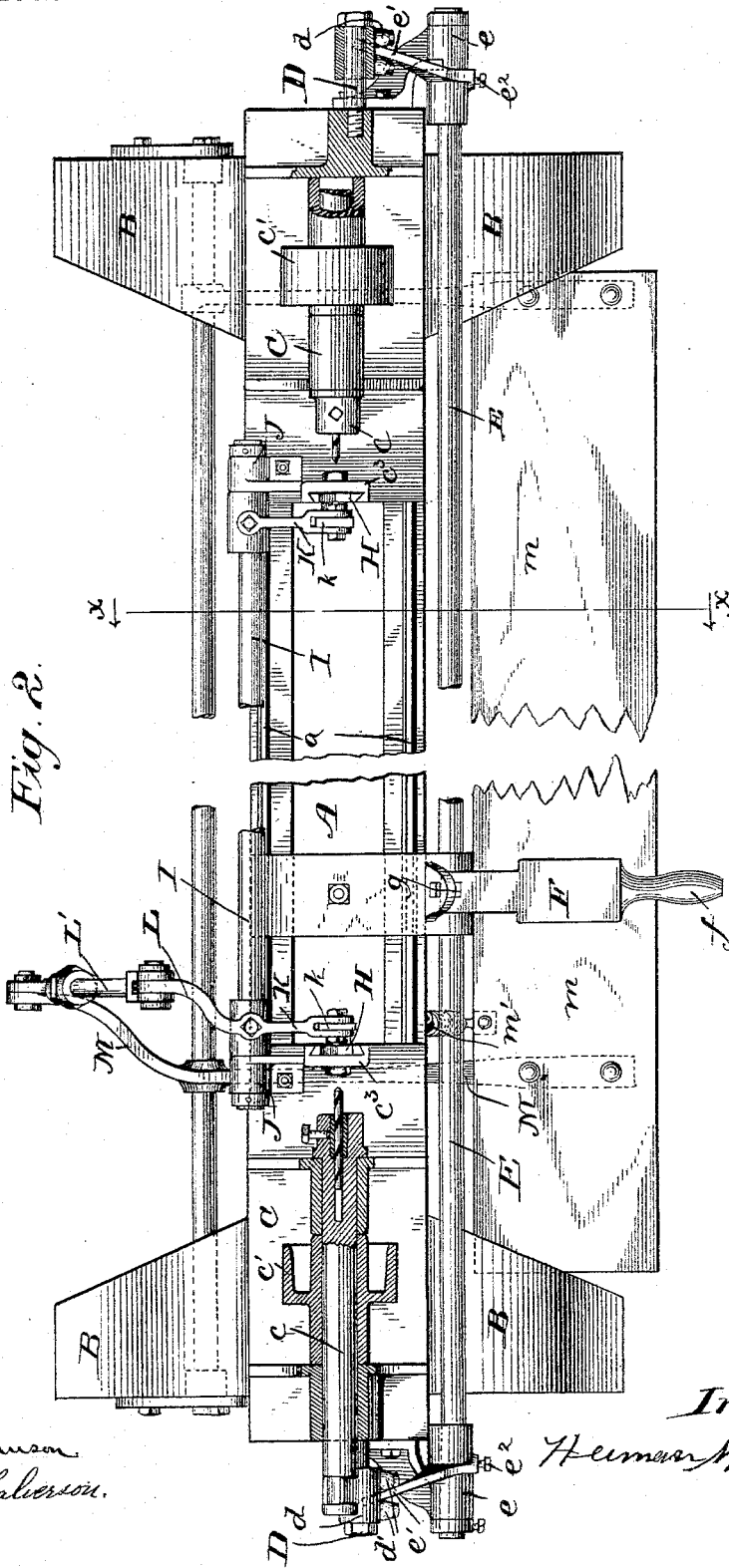

Fig. 2.

Witnesses.
Arthur Johnson
Chas. M. Halverson.

Inventor.

Herman Kennedy

(No Model.)

3 Sheets—Sheet 3.

H. N. KENNEDY.
CENTERING MACHINE.

No. 533,472.

Patented Feb. 5, 1895.

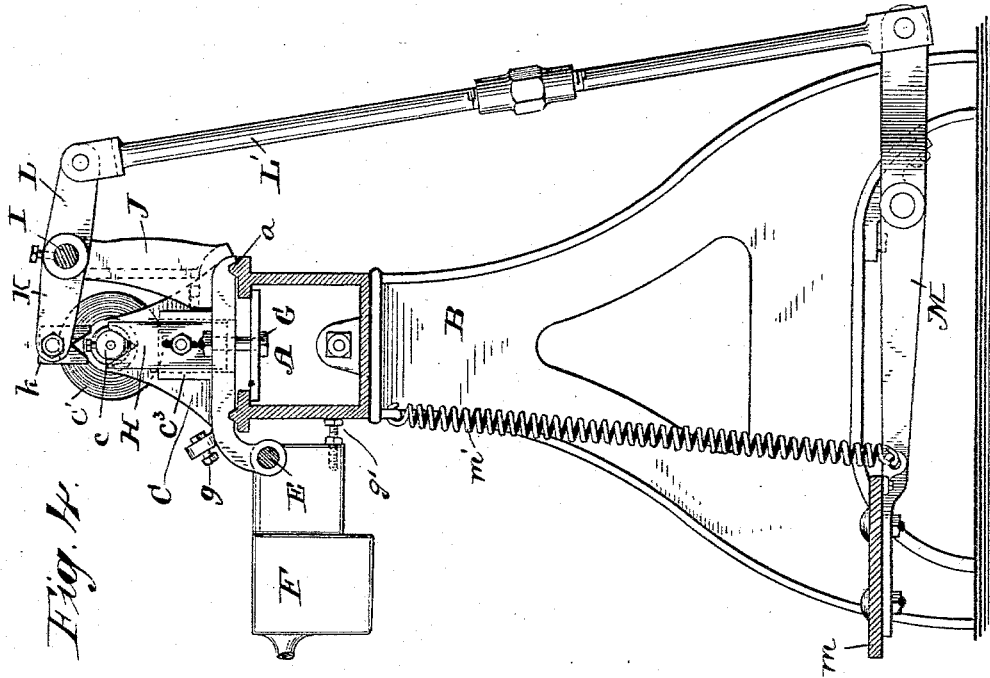

Fig. 4.

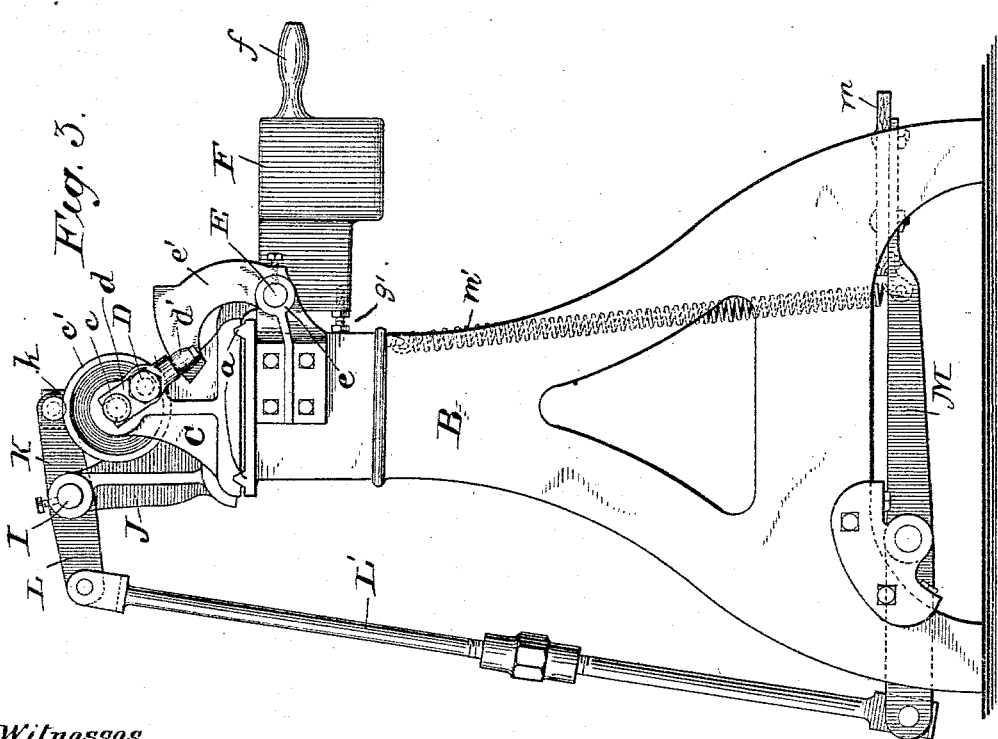

Fig. 5.

Witnesses.
Arthur Johnson.
Chas. M. Halverson.

Inventor.
Herman N. Kennedy

UNITED STATES PATENT OFFICE.

HERMAN N. KENNEDY, OF CHICAGO, ILLINOIS.

CENTERING-MACHINE.

SPECIFICATION forming part of Letters Patent No. 533,472, dated February 5, 1895.

Application filed January 13, 1892. Serial No. 417,943. (No model.)

To all whom it may concern:

Be it known that I, HERMAN N. KENNEDY, of Chicago, in the county of Cook and State of Illinois, have invented certain new and useful Improvements in Centering-Machines, of which the following is a full description, reference being had to the accompanying drawings, in which—

Figure 1 is a side elevation; Fig. 2, a plan view; Fig. 3, an end view, and Fig. 4 a sectional side view on the line X—X of Fig. 2.

The object of my invention is to provide a machine that shall center both ends of shafts simultaneously and thus prepare them for the lathe, and the bed of my machine is substantially lathe form, consisting of the bed piece A, having preferably, two V-shaped ways *a*, mounted upon the legs B—B. Upon the bed piece A, I mount the head stocks C, and in each journal a spindle *c*, adapted to take a centering drill. These spindles are adapted to slide endwise in the head stock and through the pulleys *c'*, by which it is driven, the pulley being connected to the spindle by a feather and groove in the usual manner. At a little distance below and to the front of the axes of the spindles are studs D—D, on which are adapted to slide saddle pieces *d—d*, in which a grooved portion, near the end of the spindles, rests, as shown in Fig. 2 at the left of the drawings. The movement of the saddle pieces on the studs D, causes the spindles to slide endwise. In order that they may be so slid to force the drills to their work, I provide a rock shaft E, supported in bearings *e—e*, and upon the rock shaft mount two cam-like arms, *e'*. These cams are shaped at their outer extremity like the flutes of a propeller screw, and spanning said outer margin are the anti-friction rollers *d'*, the latter adapted to rotate on pins thrust into the saddle piece D. It will be readily understood that, if power be applied to rock shaft E, the drills will be forced simultaneously toward their work or therefrom.

In order that the shaft may be rocked properly, I apply an arm F, having handle *f*, and I make the said arm very heavy so that its weight shall have the effect of withdrawing the spindles after the shaft has been centered.

I so provide that the drills shall be fed so as to bore a hole but a given depth by means of the set screw *g*.

The distance that the drills are fed I regulate by limiting the point to which the feeding lever can be elevated. To form such limit and make it adjustable I apply the set screw *g* to a lug immediately above the axis of the weighted lever. If I wish the depth to which the drills bore to be great I turn the set screw into the lug. A check-nut is shown, the use of which is simply to prevent the screw from getting loose.

g' is an adjustable set screw threaded into the feeding lever and adapted to rest against the main frame and serves as a stop.

I secure the head stocks to the bed piece by means of the bolts G, G, G, G, by loosening which they may be moved nearer to or farther from each other, so as to adapt the machine to long or short shafts. Before such adjustment can be made, however, it is necessary to loosen the set screws *e²* which hold the cam shaped arms to the rock shaft E. The arms then move with the head stocks and may be tightened in proper adjustment. At the inner ends of the head stocks are vertical lugs *c²*, and to these are secured the steel plates H, best shown in Figs. 2 and 4. They are preferably dovetailed into the lugs *c²*, and they have a V-shaped groove at their upper ends in order that the shafts may be laid into them. They are adjustable in height by slotting the hole through which the bolt passes that secures them to the lugs. Their height relative to each size of shaft operated upon must of course be such that as they lie therein the center of the shaft shall be in line with that of the drills.

In order to clamp the shafts operated upon firmly in place while being controlled, I provide a rock shaft I, pivoted in upreaching standards J—J, the latter standard being preferably secured to the head stocks so as to be adjustable therewith. Projecting to a point substantially over the shaft being operated upon are the arms K, and to the ends of these arms are bolted steel blocks *k*, having V-shaped notches in their down-hanging part. Secured to the rock shaft and reach-

ing backward, is the arm L, pivoted to which and to the pedal arm M, is the connecting rod L'. Upon the arm M is the pedal *m*, and extending from the pedal arm upward to the main frame is the spring *m'*. In order that the pedal may be reached from any part of the machine it is made quite long and two levers supported thereon, and a pivotal shaft upon which the arms turn secured near the base of the main frame.

In order that the clamping plates operated by the rock shaft I, may be adjustable as the machine is otherwise adjusted for operating upon shafts of various lengths, they are secured by set screws.

The operation of the machine is as follows: The arm F is lowered, which causes the drills to withdraw from their inwardly thrust position, and the shaft to be operated upon is laid into the V-shaped grooves in the plates H, when the operator presses upon the pedal *m* and forces the clamping pieces K downward with sufficient pressure to hold the shafts operated upon from rotating. The arm F is then raised upward, which movement forces the drills to do their work.

What I claim as my invention, and desire to secure by Letters Patent, is—

1. In a centering machine, the headstocks, adjustable to adapt the machine to center shafts of different lengths, drill-spindles journaled therein, and adapted to slide therein in order to be fed to their work, an underlying V grooved rest in which the shafts are laid, and an opposing V grooved clamp hung upon an arm, a foot lever, a rod connecting said arm and said lever, all combined substantially as described.

2. In a centering machine adjustable headstocks having journaled therein drill-spindles adapted to be fed longitudinally, suitable rests into which the shafts to be operated upon may be laid, a clamping device adapted to hold said shafts from rotation, an arm carrying said clamping device, a foot lever, a rod connecting said lever and said arm and ad-

justable in length to suit different sized shafts, all combined substantially as described.

3. In a centering machine adjustable headstocks having journaled therein drill-spindles adapted to be fed longitudinally, suitable rests into which the shafts to be operated upon may be laid, a holding clamp hung upon an arm, a foot lever suitably connected to said arm, and a spring adapted to raise said clamp when stress is removed from the foot lever, all combined substantially as described.

4. The combination of the headstock having longitudinally-moving drill-spindles, the saddle piece *d*, adapted to engage the said spindles, the cams *e'* for controlling the movement of the said saddle pieces, a rock-shaft to which said cams are secured, a feed lever secured to the said rock-shaft, substantially as and for the purpose described.

5. The combination of the longitudinally-fed drill-spindles, the saddle pieces by which they are moved, the cams controlling the movement of said saddle pieces, a rock-shaft to which the cams are secured, a feed lever secured to said rock-shaft and an adjustable stop on said lever, substantially as described.

6. The combination of the adjustable headstocks, the longitudinally-movable drill-shaft, the saddle pieces secured to the said drill-shaft and adapted to move the latter, cams for controlling the said saddle pieces, a rock-shaft to which the said cams are secured, and a weighted lever secured to the said rock-shaft, substantially as described.

7. The combination of the adjustable headstocks, the longitudinally-movable drill-shaft, the saddle pieces secured to the said drill-shaft and adapted to move the latter, cams for controlling the said saddle pieces, a rock-shaft to which the said cams are secured, said rock-shaft provided with a stop to limit its movement, substantially as described.

HERMAN N. KENNEDY.

Witnesses:

ARTHUR JOHNSON,
ELISE M. HALVERSON.